



D5™ Laser Detector

Personal/Drone Hemispheric Laser Warning

The D5™ laser warning system enhances safety and survivability in today's battlefield environment by notifying its wearer of any commercial or military targeting laser emissions. Two unique (each with 2 sensors) wide-band detectors (750 nm to 1700 nm) detect laser signals in a 200 Az by 120 El degree field and selectable audio, visual, and/or tactile feedback notify the wearer of a detection. Laser warnings can be easily integrated with ATAK or other equipment via USB-C. False detections are minimized while maintaining an ultra-fast response time of less than 50 milliseconds. The D5™ system can be worn anywhere on the body; typically, on the chest, back, or sides of a helmet. D5™ can also be used as a laser warning system on top of ground robotics or vehicle platforms as well as bottom mounted on a UAV.

Detection Range	up to 3 km for commercial LRF up to 5 km for military LRF
Field of View	200° horizontal (Az), 120° vertical (El)
Frequency Range Detection	750 nm to 1700 nm
Detection Direction	Segments in Az direction
Detection Notification	USB C port
Position	Compass, 3D orientation, Accelerometers
Power	USB C port 5V
Size	75 x 29 x 25 mm
Weight	39 g per unit
Mounting	Velcro strap, extension arm or mounting screws

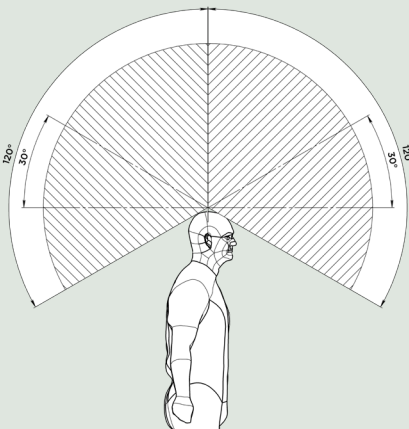

BENEFITS AT A GLANCE

D5™ system is designed as a body or helmet-mounted aid to warn the user of a laser event alarms caused by:

- Laser rangefinder systems, both commercial and military
- UAV (drone) ranging or targeting equipment
- Handheld and rifle mounted NVG illuminators and pointers
- Variety of visible and invisible laser markers and designators used in the battlefield environment
- Mitigate friendly fire incidents by alerting the user of a laser illumination
- ATAK interface integrated orientation, detection and motion into threat display

